

Version : 1.0

TECHNICAL SPECIFICATION

MODEL NO. : PD057VU4

Customer's Confirmation

Customer _____

Date _____

By _____

PVI's Confirmation

FOR MORE INFORMATION:

AZ DISPLAYS, INC.
75 COLUMBIA, ALISO VIEJO, CA, 92656
[Http://www.AZDISPLAYS.com](http://www.AZDISPLAYS.com)

Dep	FAE	Panel Design	Electronic Design	Mechanical Design	Product Verification	Prepared by
SIGN	劉豐茂 9/16	劉金 8/10/16	楊秉翰 9/10 金和坤	申峰 9/16 鄭志強 9/16	張天 9/16	吳昌霖

TECHNICAL SPECIFICATION

CONTENTS

NO.	ITEM	PAGE
-	Cover	1
-	Contents	2
1	Application	3
2	Features	3
3	Mechanical Specifications	3
4	Mechanical Drawing of TFT-LCD module	4
5	Input / Output Terminals	5
6	Absolute Maximum Ratings	6
7	Electrical Characteristics	6
8	Pixel Arrangement	7
9	Display Color and Gray Scale Reference	8
10	Interface Timing	9
11	Power On Sequence	12
12	Optical Characteristics	12
13	Handling Cautions	15
14	Reliability Test	16
15	Packing Diagram	17
-	Revision History	18

1. Application

This data sheet applies to a color TFT LCD module, PD057VU4.

PD057VU4 module applies to OA product, car TV (must use Analog to Digital driving board), which requires high quality flat panel display. If you must use in severe reliability environment, please don't extend over PVI's reliability test conditions.

2. Features

- . QVGA (320*240 pixels) resolution
- . Amorphous silicon TFT LCD panel with back-light unit
- . Pixel in stripe configuration
- . Thin and light weight
- . Display Colors : 262,144 colors
- . Optimum Viewing Direction : 6 o'clock
- . TTL interface

3. Mechanical Specifications

Parameter	Specifications	Unit
Screen Size	5.7 (diagonal)	inch
Display Format	320×(R,G,B)×240	dot
Display Colors	262,144	
Active Area	115.20 (H)×86.4 (V)	mm
Pixel Pitch	0.36(H)×0.36(V)	mm
Pixel Configuration	Stripe	
Outline Dimension	144(W)×104.6 (H)×13.0 (D) (typ.)	mm
Weight	202±10	g
Back-light	CCFL, 1 tube	
Surface treatment	Anti-glare + wide view film	
Display mode	Normally white	

4.Mechanical Drawing of TFT-LCD Module
Outline Drawing : Front View (unit : mm)

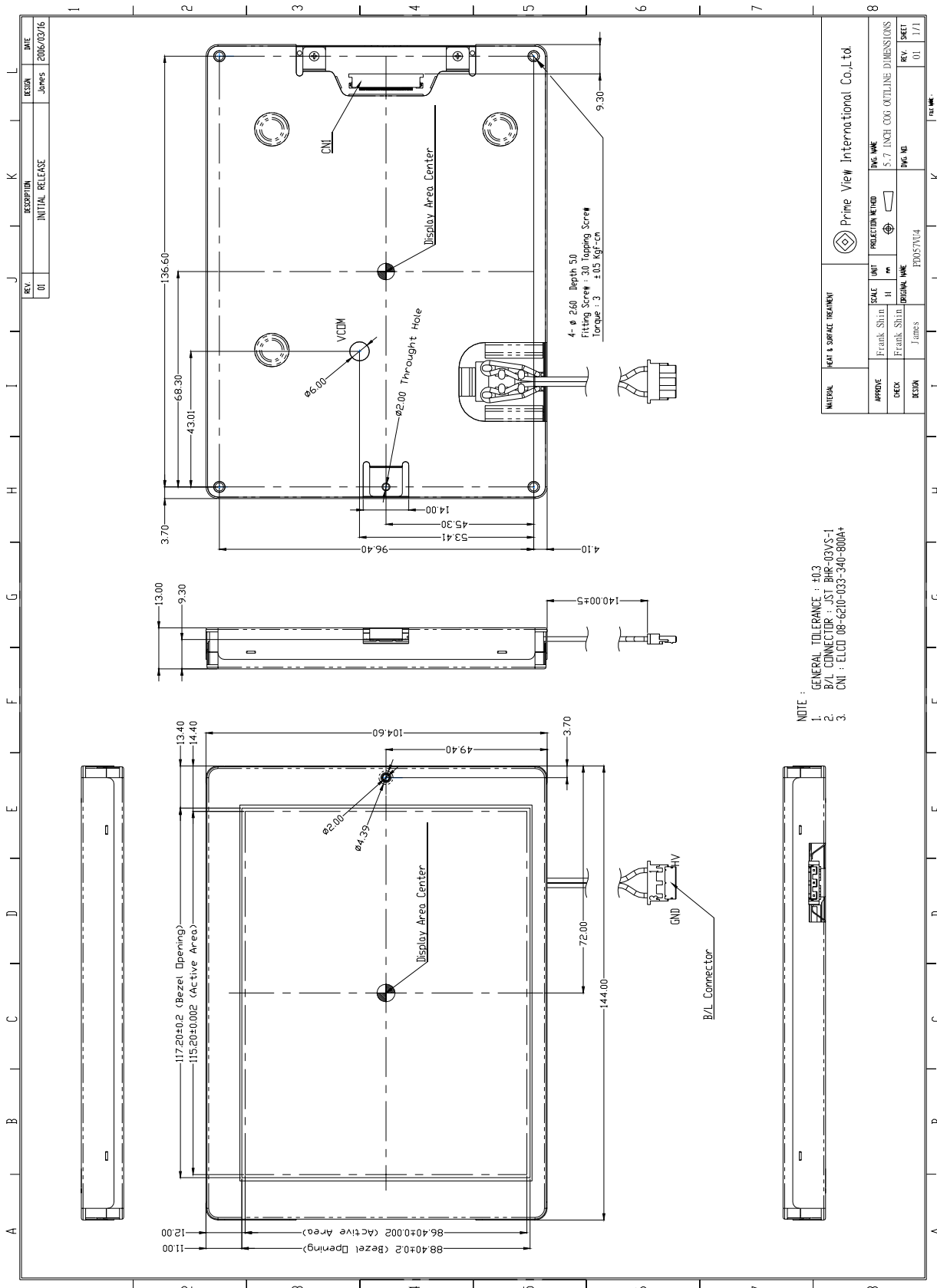

NOTE :
 GENERAL TOLERANCE : ±0.3
 1. B/L CONNECTOR : JST BHR-03VS-1
 3. CNI : ELCD 08-6210-033-340-800A+

MATERIAL		HEAT & SURFACE TREATMENT		PRIME VIEW INTERNATIONAL CO., LTD.	
APPROVE	SCALE	UNIT	PROJECTION METHOD	DWG. NAME	5.7 INCH COG OUTLINE DIMENSIONS
FRANK SHIH	1:1	mm	1st ANGLE	DWG. NO.	PD057VU4
CHECK	ORIGINAL NAME	DESIGNER	DATE	REV.	SHEET
FRANK SHIH	PRIME VIEW	JAMES	2016/02/16	01	1/1

5.Input / Output Terminals
5-1) TFT-LCD Panel Driving

Connector type: ELCO 08-6210-033-340-800A+ , PIN No 33 pins, pitch=0.5mm

Pin No	Symbol	I/O	Description	Remark
1	GND	-	GND	
2	CK	I	Clock signal for sampling each data signal	
3	Hsync	I	Horizontal synchronous signal(neqative)	
4	Vsync	I	Vertical synchronous signal(neqative)	
5	GND	-	GND	
6	R0		RED data signal(LSB)	
7	R1	I	RED data signal	
8	R2	I	RED data signal	
9	R3	I	RED data signal	
10	R4	I	RED data signal	
11	R5	I	RED data signal(MSB)	
12	GND	-	GND	
13	G0	I	GREEN data signal(LSB)	
14	G1	I	GREEN data signal	
15	G2	I	GREEN data signal	
16	G3	I	GREEN data signal	
17	G4	I	GREEN data signal	
18	G5	I	GREEN data signal(MSB)	
19	GND	-	GND	
20	B0	I	Blue data signal(LSB)	
21	B1	I	Blue data signal	
22	B2	I	Blue data signal	
23	B3	I	Blue data signal	
24	B4	I	Blue data signal	
25	B5	I	Blue data signal(MSB)	
26	GND	-	GND	
27	ENAB	I	Signal to settle the horizontal display position(positive)	Note5-1
28	V _{CC}	-	+3.3V power supply	
29	V _{CC}	-	+3.3V power supply	
30	R/L	I	Horizontal display mode select signal L : Normal ,H : Left /Right reverse mode	Note5-2
31	U/D	I	Vertical display mode select signal H : Normal ,L :Up/Down reverse mode	Note5-3
32	V/Q	I	VGA / QVGA mode select signal	
33	GND	-	GND	

Note5-1 : The horizontal display start timing is settled in accordance with rising of ENAB signal.

In case ENAB is fixed "Low", the horizontal start timing is determined as described in 10-2. Don't keep ENAB "High" during operation.

Note 5-2 , 5-3 : The definitions of U/D & R/L

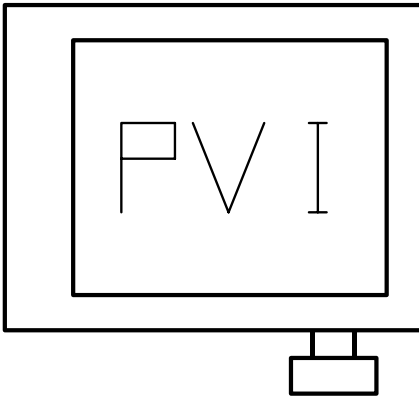

R/L(PIN 30)= Low, U/D(PIN 31)= High

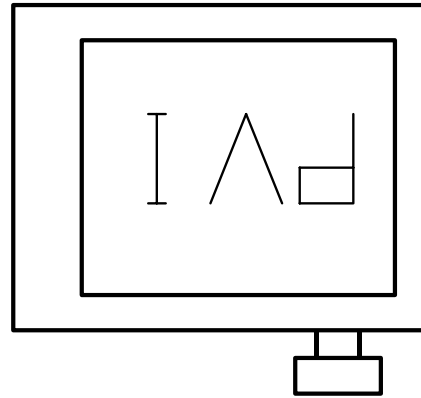

R/L(PIN 30)= High , U/D(PIN 31)= Low

5-2) Backlight driving

Connector type: JST BHR-03VS-1, PIN No 2 pins, pitch=3.5mm

Pin No	Symbol	Description	Remark
1	V _{Low}	Power supply for lamp (Low voltage side)	White
-	NC	This is electrically opened	-
2	V _{High}	Power supply for lamp (High voltage side)	Red

Note 5-11: Low voltage side of backlight inverter connects with ground of inverter circuits.

6.Absolute Maximum Ratings:

GND=0V, Ta=25°C

Parameters	Symbol	Condition	MAX.	Unit	Remark
Input Voltage	V _I	Ta=25°C	-0.3~+4	V	Note6-1
+3.3V supply voltage	V _{CC}	Ta=25°C	0~+3.6	V	

Note6-1:CK,R0~R5,G0~G5,B0~B5,Hsync,Vsync,ENAB,R/L,U/D,V/Q

7.Electrical Characteristics

7-1) Recommended Operating Conditions:

GND=0V, Ta=25°C

Item	Symbol	Min.	Typ.	Max.	Unit	Remark
+3.3V Supply Voltage	V _{CC}	+3.0	+3.3	+3.6	V	
Permissive input ripple voltage	V _{RF}	-	-	100	mVp-p	V _{CC} =3.3V
Input voltage(Low)	V _{IL}	0	-	0.3 V _{CC}	V	
Input voltage(High)	V _{IH}	0.7 V _{CC}	-	V _{CC}	V	

7-2) Recommended Driving Condition for Back Light

Ta=25°C

Parameter	Symbol	Min.	Typ.	Max.	Unit	Remark
Lamp Voltage	V_L	639	710	781	V	$I_L=5mA$
Lamp Current	I_L	4	5	8	mA	Note 7-1
Lamp Frequency	P_L	-	35	-	KHz	Note 7-2
Starting Voltage (25°C) (Reference Value)	V_s	-	-	1240	Vrms	Note 7-3
Starting Voltage (0°C) (Reference Value)	V_s	-	-	1380	Vrms	Note 7-3

Note 7-1 : In order to have proper operation of the B/L, no matter what kind of inverters, the output lamp current must be between Min. and Max. values to avoid the abnormal display image caused by B/L.

Note 7-2 : The driving frequency of the lamp may interfere with the horizontal synch signal, leaving interference stripes on the display. So please evaluate LCD panels beforehand.

To avoid interference stripes, we recommend to separate as far as possible the lamp frequency from the horizontal synchronous signal and its high harmonic frequency.

The inverter which PVI uses is TAD347-1.

Note 7-3 : The “Starting Voltage” means the minimum voltage of inverter to turn on the lamp. And it should be applied to the lamp for more than 1 second to start up. Otherwise the lamp may not be turned on.

7-3) Power Consumption

Parameters	Symbol	Typ.	Max.	Unit	Remark
+3.3V Current Dissipation	I_{CC}	67	75	mA	
LCD Panel Power Consumption	-	0.22	0.25	W	Note 7-4
Backlight Power Consumption	-	3.55	3.91	W	Note 7-5

Note 7-4: The power consumption for back light is not included.

Note 7-5: Back light lamp power consumption is calculated by $I_L \times V_L$.

8. Pixel Arrangement

The LCD module pixel arrangement is stripe configuration.

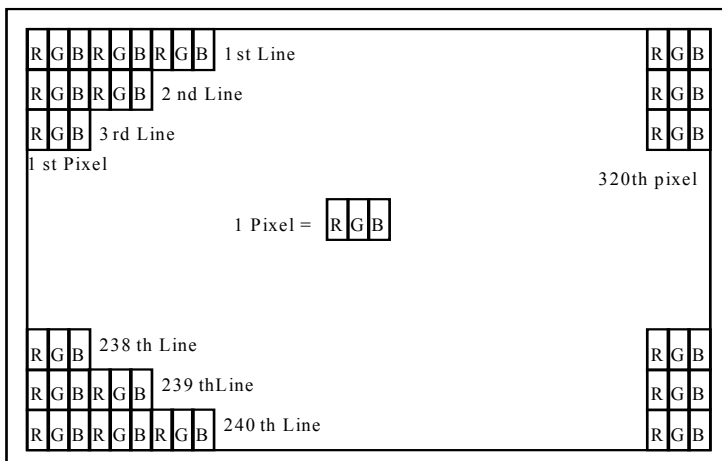

9. Display Color and Gray Scale Reference

Color		Input Color Data																	
		Red						Green						Blue					
		R5	R4	R3	R2	R1	R0	G5	G4	G3	G2	G1	G0	B5	B4	B3	B2	B1	B0
Basic Colors	Black	0	0	0	0	0	0	0	0	0	0	0	0	0	0	0	0	0	0
	Red (63)	1	1	1	1	1	1	0	0	0	0	0	0	0	0	0	0	0	0
	Green (63)	0	0	0	0	0	0	1	1	1	1	1	1	0	0	0	0	0	0
	Blue (63)	0	0	0	0	0	0	0	0	0	0	0	0	1	1	1	1	1	1
	Cyan	0	0	0	0	0	0	1	1	1	1	1	1	1	1	1	1	1	1
	Magenta	1	1	1	1	1	1	0	0	0	0	0	0	1	1	1	1	1	1
	Yellow	1	1	1	1	1	1	1	1	1	1	1	1	0	0	0	0	0	0
	White	1	1	1	1	1	1	1	1	1	1	1	1	1	1	1	1	1	1
Red	Red (00)	0	0	0	0	0	0	0	0	0	0	0	0	0	0	0	0	0	0
	Red (01)	0	0	0	0	0	1	0	0	0	0	0	0	0	0	0	0	0	0
	Red (02)	0	0	0	0	1	0	0	0	0	0	0	0	0	0	0	0	0	0
	Darker																		
	↓	↓	↓	↓	↓	↓	↓	↓	↓	↓	↓	↓	↓	↓	↓	↓	↓	↓	↓
	Brighter																		
	Red (61)	1	1	1	1	0	1	0	0	0	0	0	0	0	0	0	0	0	0
	Red (62)	1	1	1	1	1	0	0	0	0	0	0	0	0	0	0	0	0	0
Red (63)	1	1	1	1	1	1	0	0	0	0	0	0	0	0	0	0	0	0	
Green	Green (00)	0	0	0	0	0	0	0	0	0	0	0	0	0	0	0	0	0	0
	Green (01)	0	0	0	0	0	0	0	0	0	0	0	1	0	0	0	0	0	0
	Green (02)	0	0	0	0	0	0	0	0	0	0	1	0	0	0	0	0	0	0
	Darker																		
	↓	↓	↓	↓	↓	↓	↓	↓	↓	↓	↓	↓	↓	↓	↓	↓	↓	↓	↓
	Brighter																		
	Green (61)	0	0	0	0	0	0	1	1	1	1	0	1	0	0	0	0	0	0
	Green (62)	0	0	0	0	0	0	1	1	1	1	1	0	0	0	0	0	0	0
Green (63)	0	0	0	0	0	0	1	1	1	1	1	1	0	0	0	0	0	0	
Blue	Blue (00)	0	0	0	0	0	0	0	0	0	0	0	0	0	0	0	0	0	0
	Blue (01)	0	0	0	0	0	0	0	0	0	0	0	0	0	0	0	0	0	1
	Blue (02)	0	0	0	0	0	0	0	0	0	0	0	0	0	0	0	0	1	0
	Darker																		
	↓	↓	↓	↓	↓	↓	↓	↓	↓	↓	↓	↓	↓	↓	↓	↓	↓	↓	↓
	Brighter																		
	Blue (61)	0	0	0	0	0	0	0	0	0	0	0	0	1	1	1	1	0	1
	Blue (62)	0	0	0	0	0	0	0	0	0	0	0	0	1	1	1	1	1	0
Blue (63)	0	0	0	0	0	0	0	0	0	0	0	0	1	1	1	1	1	1	

10. Interface Timing
10-1) Timing Parameters

 AC Electrical Characteristics ($V_{CC} = +3.3V, GND = 0V, T_a = 25^{\circ}C$)

Characteristics		Symbol	Min.	Typ.	Max.	Unit	Remark
Clock	Frequency	1/Tc	-	25.18	28.33	MHz	V/Q=H
			-	6.3	7.0	MHz	V/Q=L
	Duty ratio	Tch/Tc	40	50	60	%	V/Q=L
Data	Set up time	Tds	5	-	-	ns	
	Hold time	Tdh	10	-	-		
Horizontal sync. signal	Cycle	TH	30.0	31.8	-	us	V/Q=H
			700	800	900		
		TH	50.0	63.6	-	us	V/Q=L
			360	400	450		
Pulse width	THp	2	96	200	clock		
Vertical sync. signal	Cycle	TV	515	525	560	line	V/Q=H
			251	262	280		V/Q=L
	Pulse width	TVp	2	-	34	line	
Horizontal display period		THd	320			Clock	
Hsync.-Clock phase difference		THc	10	-	Tc-10	ns	
Hsync.-Vsync. phase difference		TVh	0	-	TH-THp	ns	
Vertical sync. signal start position		TVs	34			line	V/Q=H
			7				V/Q=L

Note10-1 : In case of lower frequency, the deterioration of the display quality, flicker etc., may occur.

Parameter		symbol	Min.	Typ	Max	Unit	Remark
Enable signal	Set up time	Tes	5	-	Tc-10	ns	
	Pulse width	Tep	2	320	TH-10	clock	
Hsync-Enable signal phase difference		The	44	-	TH-664	clock	V/Q=H
			2	-	TH-340		V/Q=L

Note10-2 :

When ENAB is fixed at "V/Q=Low", the display starts from the data of C52 (clock).

When ENAB is fixed at "V/Q=High", the display starts from the data of C104 (clock).

10-2) Timing Diagram

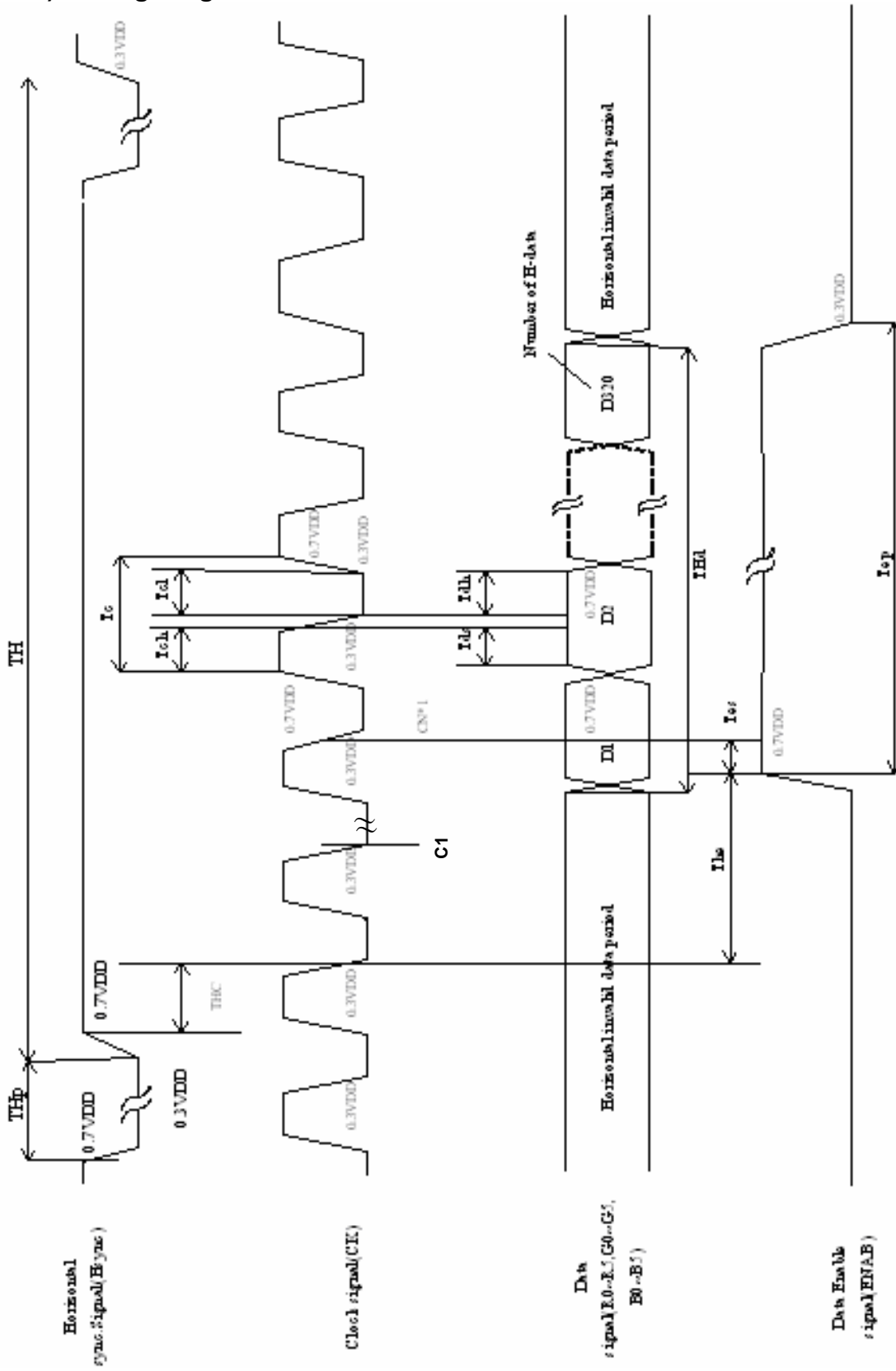

*1 When ENAB is fired to 'Low' at V_{CC}= 'H', the display starts from data of C10+ (Clock)
 When ENAB is fired to 'Low' at V_{CC}= 'L', the display starts from data of C12 (Clock)

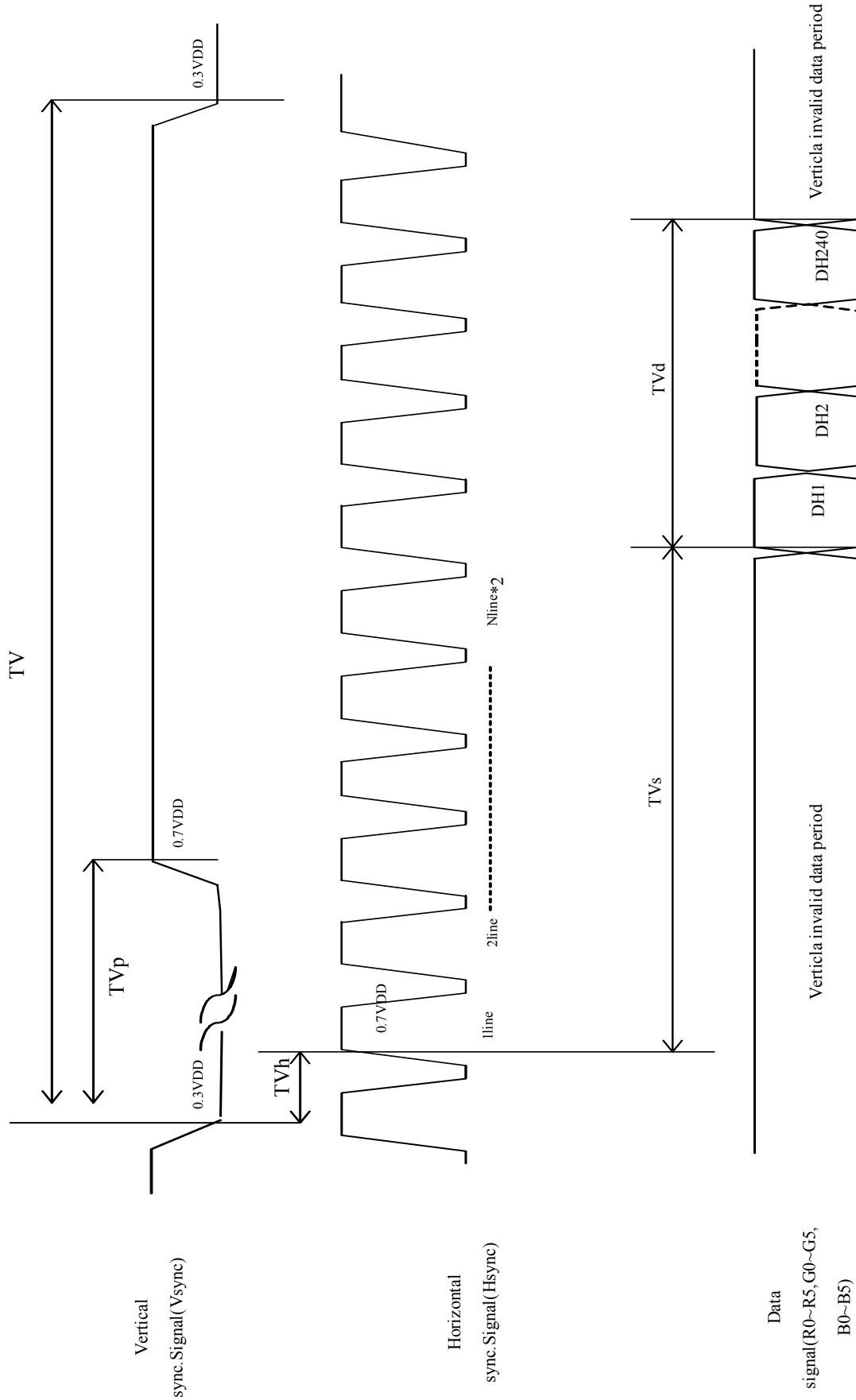

*2 The vertical display position (TVs) is fixed at 34th line (V/Q=H) and 7th line (V/Q=L).

11. Power On Sequence

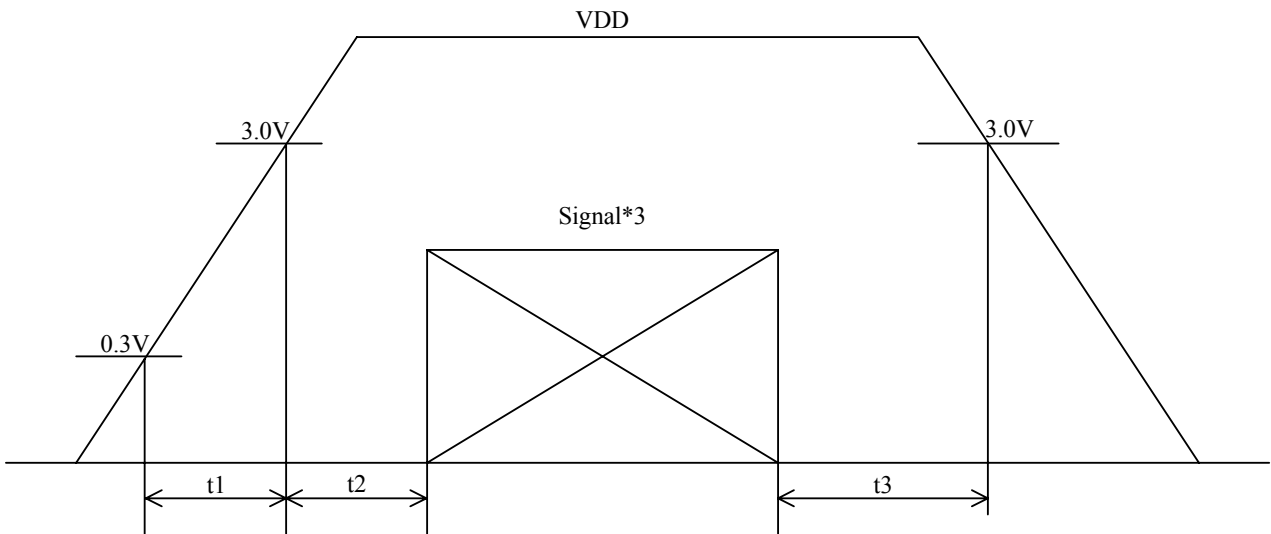

1. $0 < t1 \leq 20\text{ms}$
2. $0 < t2 \leq 50\text{ms}$
3. $0 < t3 \leq 1\text{s}$

12. Optical Characteristics

12-1) Specification:

Ta=25°C

Parameter		Symbol	Condition	MIN.	TYP.	MAX.	Unit	Remarks
Viewing Angle	Horizontal	θ	CR ≥ 10	55	60	-	deg	Note 12-1
	Vertical	θ (to 6 o'clock)		45	50	-	deg	
		θ (to 12 o'clock)		35	40	-	deg	
Contrast Ratio		CR	At optimized viewing angle	200	400	-	-	Note 12-2
Response time	Rise	Tr	$\theta = 0^\circ$	-	15	30	ms	Note 12-3
	Fall	Tf		-	25	50	ms	
Brightness		-	$\theta = 0^\circ / \varphi = 0$	450	500	-	cd/m ²	Note 12-4
Luminance Uniformity		U%		75	80	-	%	Note 12-5
White Chromaticity		x		0.29	0.32	0.35	-	
		y		0.33	0.36	0.39	-	
Lamp Life Time		-		-	50000	-	hr	At=5mA

Note 12-1: The definitions of viewing angles are as follow

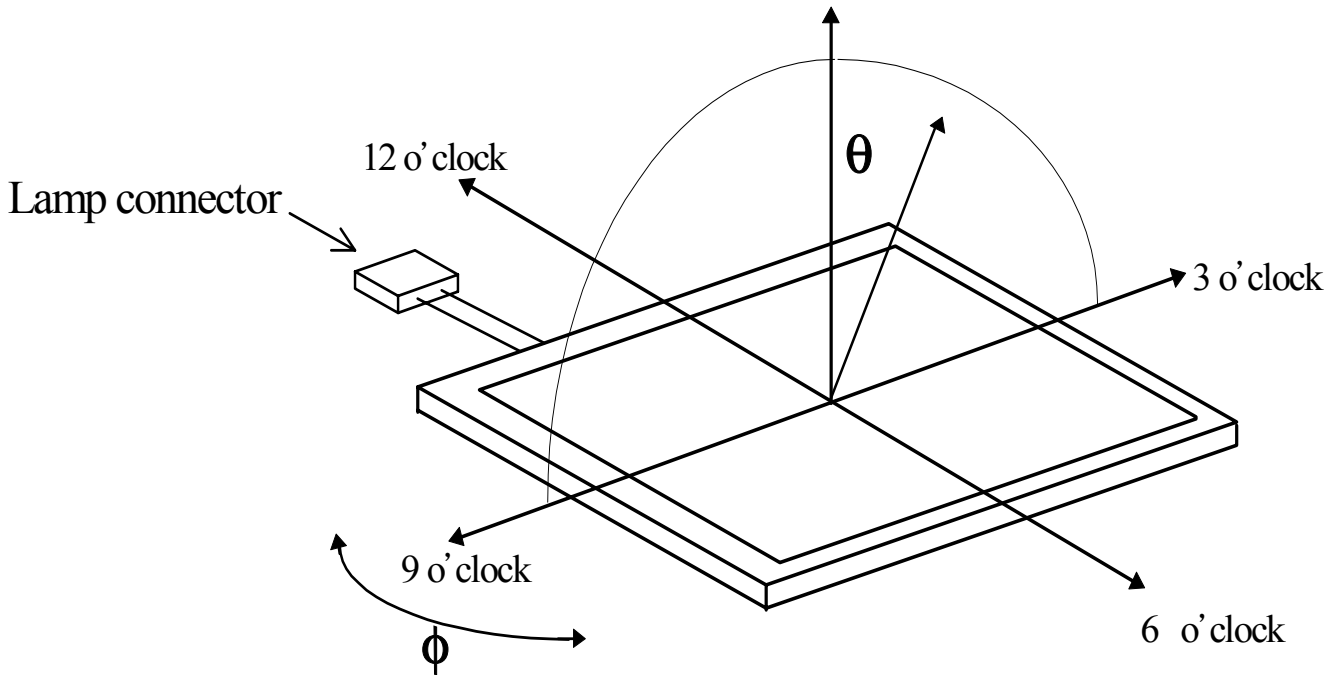

Note 12-2: The definition of contrast ratio $CR = \frac{\text{Luminance at gray level 63}}{\text{Luminance at gray level 0}}$

Note 12-3: Definition of Response Time T_r and T_f :

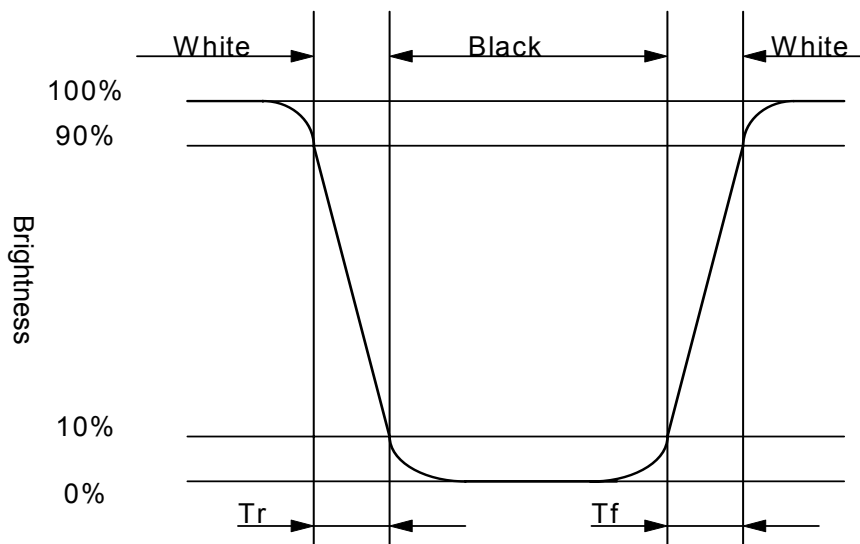

Note 12-4: All optical measurements shall be performed after backlight being turned-on for 30 mins. The optical characteristics shall be measured in dark room (ambient illumination on panel surface less than 1 Lux). The measuring configuration shows as following figure.

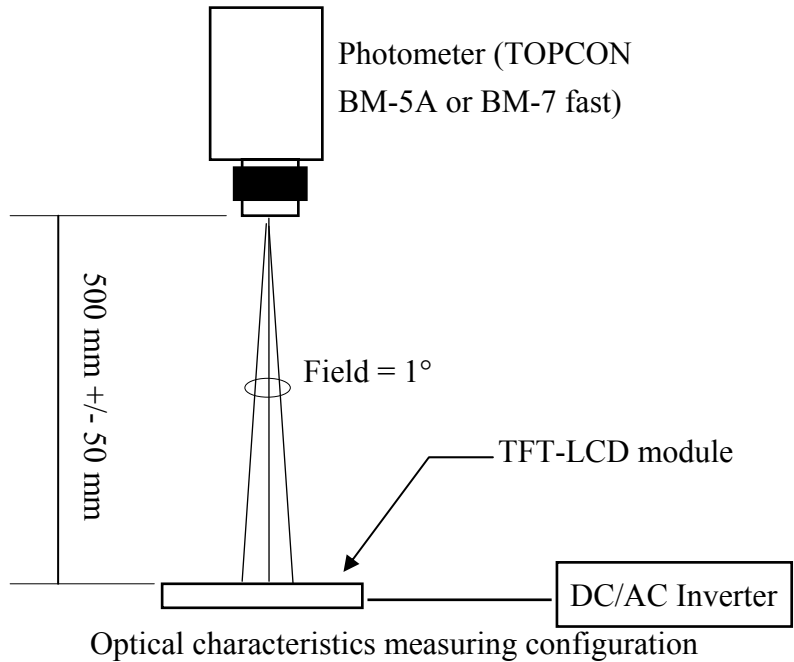

Note 12-5: The uniformity of LCD is defined as

$$U = \frac{\text{The Minimum Brightness of the 9 testing Points}}{\text{The Maximum Brightness of the 9 testing Points}}$$

Luminance meter: BM-5A or BM-7 fast (TOPCON)

Measurement distance: 500 mm +/- 50 mm

Ambient illumination: < 1 Lux

Measuring direction: Perpendicular to the surface of module

The test pattern is white (Gray Level 63).

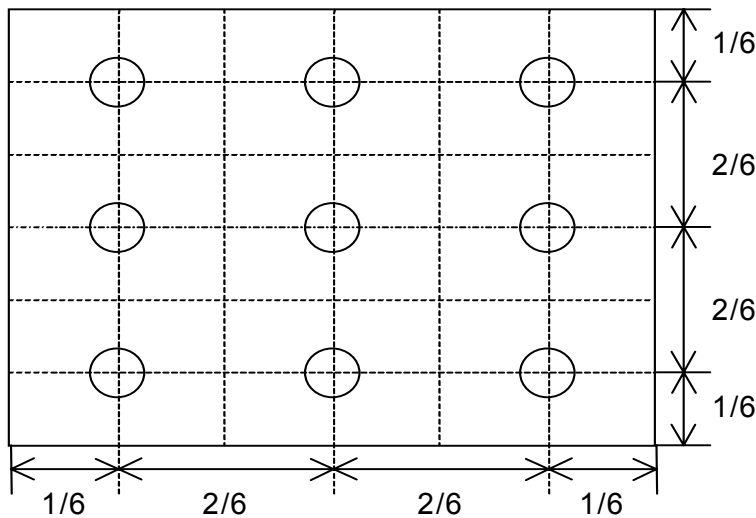

13. Handling Cautions**13-1) Mounting of module**

- a) Please power off the module when you connect the input/output connector.
- b) Please connect the ground pattern of the inverter circuit surely. If the connection is not perfect, some following problems may happen possibly.
 - 1. The noise from the backlight unit will increase.
 - 2. The output from inverter circuit will be unstable.
 - 3. In some cases a part of module will heat.
- c) Polarizer which is made of soft material and susceptible to flaw must be handled carefully.
- d) Protective film (Laminator) is applied on surface to protect it against scratches and dirt. It is recommended to peel off the laminator before use and taking care of static electricity.

13-2) Precautions in mounting

- a) When metal part of the TFT-LCD module (shielding lid and rear case) is soiled, wipe it with soft dry cloth.
- b) Wipe off water drops or finger grease immediately. Long contact with water may cause discoloration or spots.
- c) TFT-LCD module uses glass which breaks or cracks easily if dropped or bumped on hard surface. Please handle with care.
- d) Since CMOS LSI is used in the module. So take care of static electricity and earth yourself when handling.

13-3) Adjusting module

- a) Adjusting volumes on the rear face of the module have been set optimally before shipment.
- b) Therefore, do not change any adjusted values. If adjusted values are changed, the specifications described may not be satisfied.

13-4) Others

- a) Do not expose the module to direct sunlight or intensive ultraviolet rays for many hours.
- b) Store the module at a room temperature place.
- c) The voltage of beginning electric discharge may over the normal voltage because of leakage current from approach conductor by to draw lump read lead line around.
- d) If LCD panel breaks, it is possibly that the liquid crystal escapes from the panel. Avoid putting it into eyes or mouth. When liquid crystal sticks on hands, clothes or feet. Wash it out immediately with soap.
- e) Observe all other precautionary requirements in handling general electronic components.
- f) Please adjust the voltage of common electrode as material of attachment by 1 module.

13-5) Polarizer mark

The polarizer mark is to describe the direction of wide view angle film how to match up with the rubbing direction.

14. Reliability Test

No	Test Item	Test Condition	Remark
1	High Temperature Storage Test	Ta = +80°C, 240 hrs	
2	Low Temperature Storage Test	Ta = -30°C, 240 hrs	
3	High Temperature Operation Test	Ta = +70°C, 240 hrs	
4	Low Temperature Operation Test	Ta = -20°C, 240 hrs	
5	High Temperature & High Humidity Operation Test	Ta = +60°C, 90%RH, 240 hrs (No Condensation)	
6	Thermal Cycling Test (non-operating)	-20°C → +70°C, 200 Cycles 30 min 30 min	
7	Vibration Test (non-operating)	Frequency: 10 ~ 57 Hz / Vibration Width: 0.075mm 58-500 Hz / Gravity: 9.8m/s ² Sweep time: 11 minutes Test period: 3 hrs for each direction of X, Y, Z	
8	Shock Test (non-operating)	Gravity: 490m/s ² * 6ms Direction: ±X, ±Y, ±Z Pulse Width: 11ms, half sine wave	
9	Electrostatic Discharge Test (non-operating)	Machine Mode = ±200V C = 200pF, R = 0Ω 1 times discharge for each pad	

Ta: ambient temperature

Note: The protective film must be removed before temperature test

[Criteria]

1. Main LCD should normally work under the normally condition no defect of function, screen quality and appearance (including : Mura ,line defect ,no image)
2. After the temperature and humidity test, the luminance and CR (Contrast ratio), should not be lower than minimum of specification.
3. After the vibration and shock test, can't be found chip broken.

15. Packing Diagram

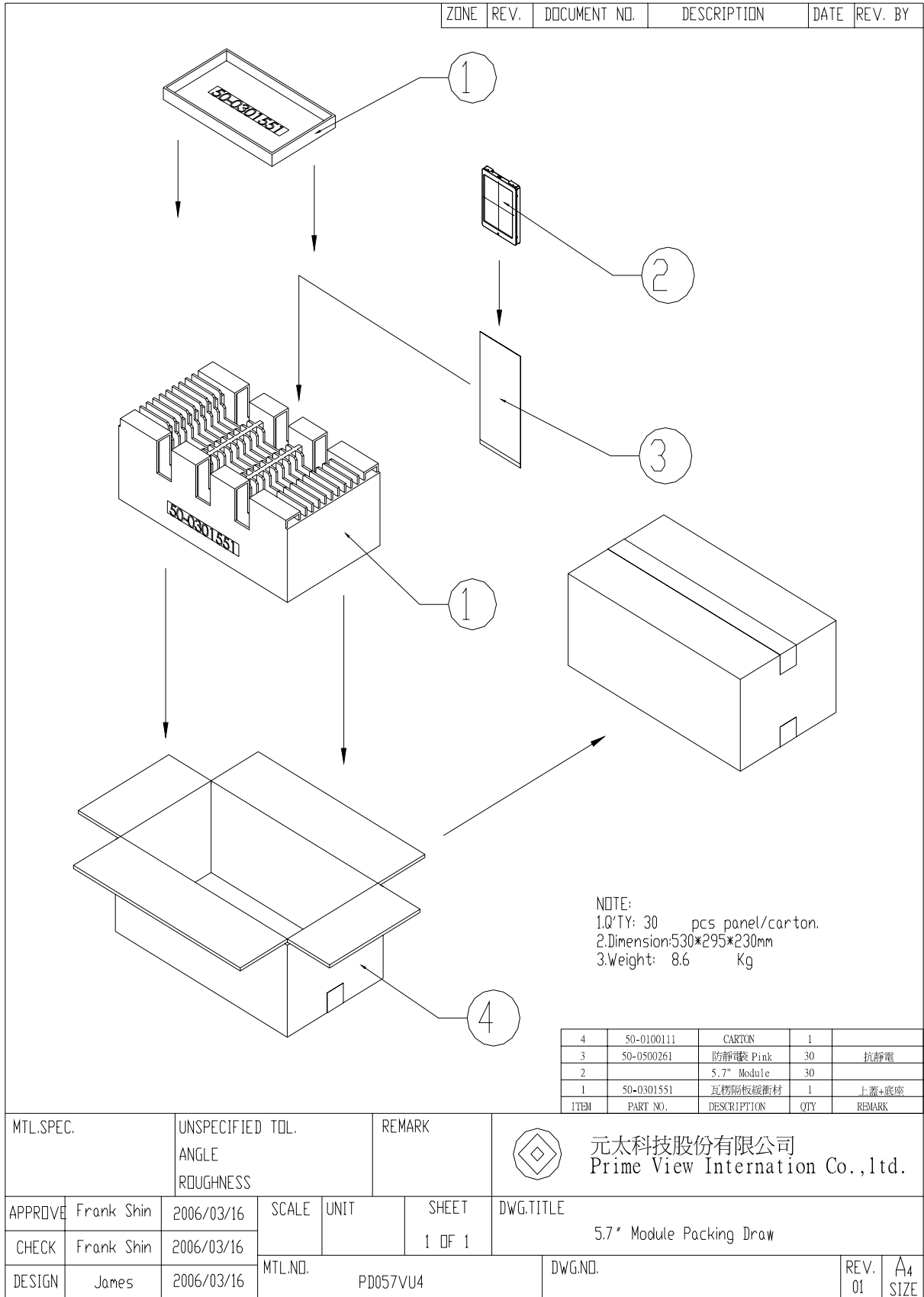

Revision History

Rev.	Issued Date	Revised	Contents
1.0	Jul.11, 2006	preliminary	